

ALTEC®

RESERVDELSBOK

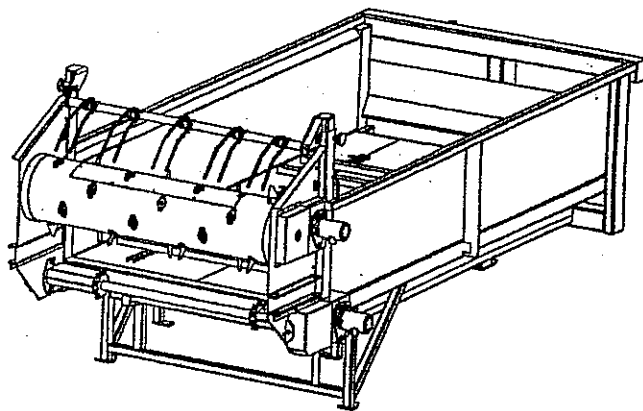

DT120



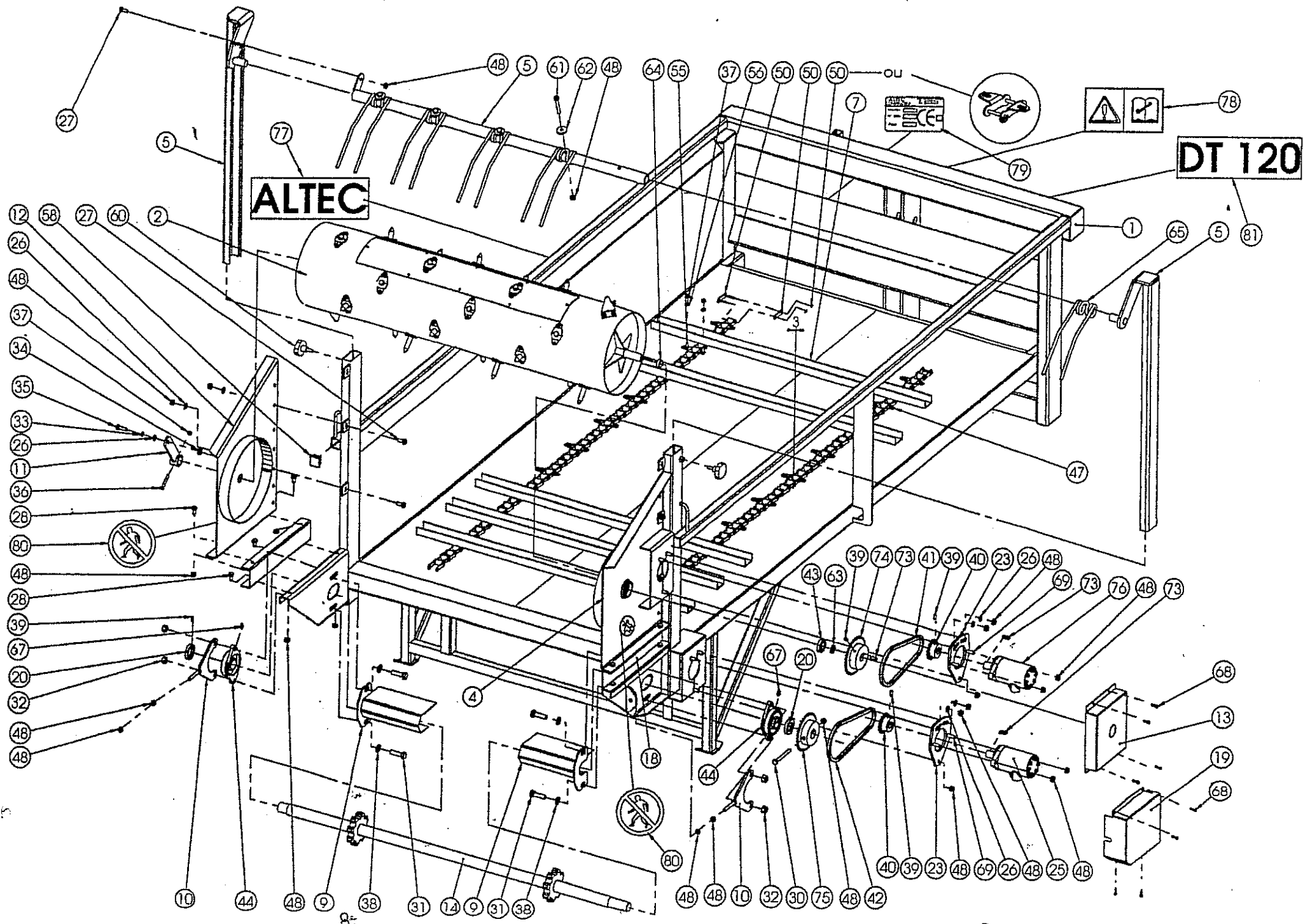

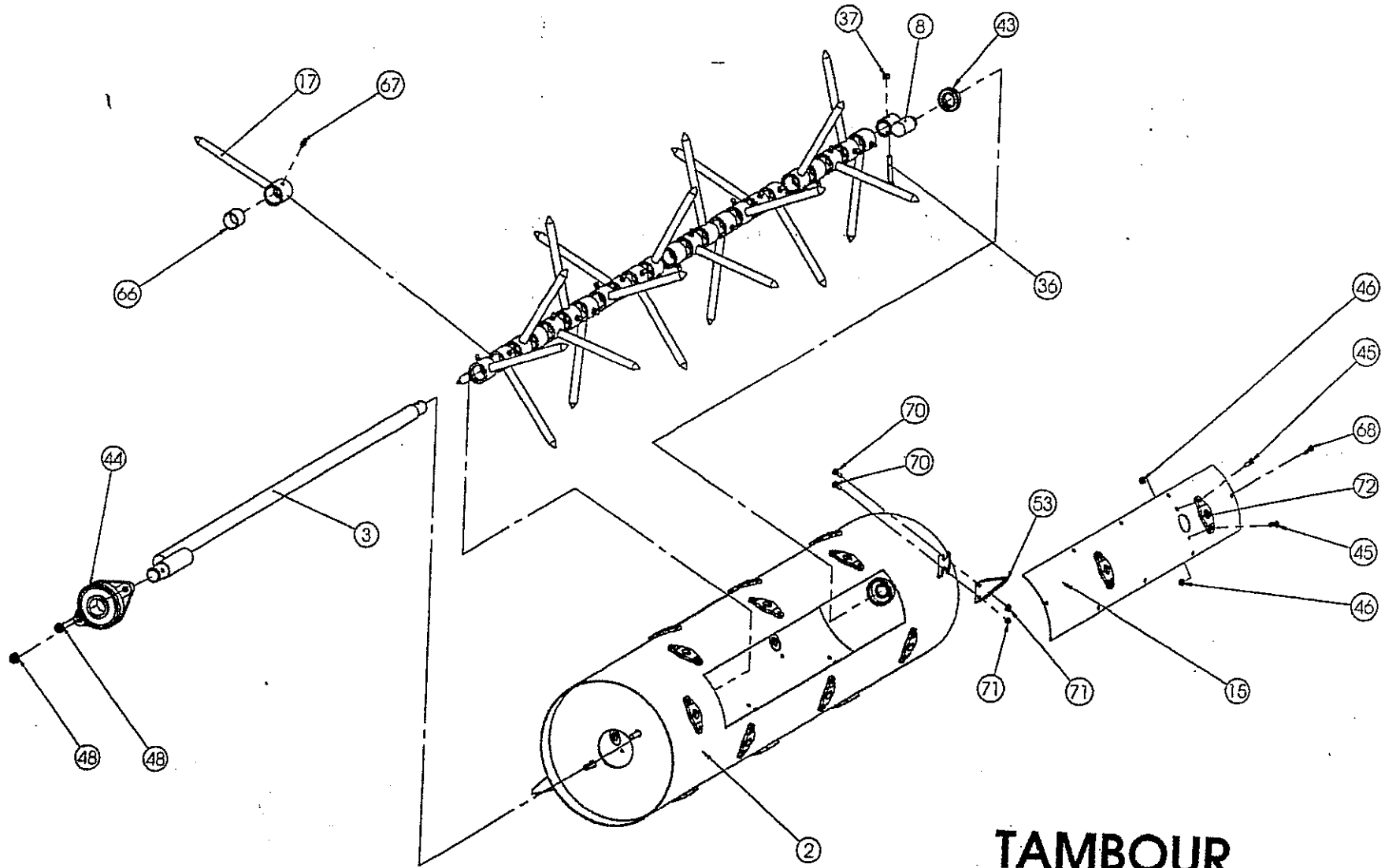

TAMBOUR

PIECES DETACHEES DT 120

REPÈRE	CODE ARTICLE	QUANTITÉ	DESCRIPTION
1	DN 10 00	1	CHÂSSIS
2	DN 02 00	1	TAMBOUR
3	DN 03 00	1	CAME
4	DN 04 00	1	JOUE COTE MOTEUR
5	DN 05 00	1	PEIGNE
6			
7	DN 07 00	17	BARRETTES
8	DN 08 00	1	EXCENTRIQUE
9	DN 09 00	2	CACHE ANTI-ENROULEMENT
10	DN 10 00	2	TENDEUR DE CHAÎNE
11	DN 11 00	1	RÉGLAGE CAME
12	DN 12 00	1	JOUE COTE OPPOSE AU MOTEUR
13	DN 13 00	1	CARTER ENTRAÎNEMENT TAMBOUR
14	DN 14 00	1	ARBRE D'ENTRAÎNEMENT TAPIS
15	DN 15 00	1	COUVERCLE TAMBOUR
16			
17	DN 17 00	24	DOIGTS ESCAMOTABLES
18	DN 18 00	2	ENTRETOISE TAMBOUR
19	DN 19 00	1	CACHE ENTRAÎNEMENT TAPIS
20	DN 20 00		
21	DN 21 00	1	CACHE FLEXIBLE LONG
22	DN 22 00	1	CACHE FLEXIBLE COURT
23	DO 66 00	1	BARRE D'ATELAGE
24			
25	918600400	1	MOTEUR OMP 400
26	935520005	9	RONDELLE ISO 7089 - 10 - 140 HV
27	931510025	5	VIS A METAUX - HM10x25 - 8,8
28	931510020	8	VIS A METAUX - HM10x20 - 8,8
30	931510100	1	VIS A METAUX - HM10x100 - 8,8
31	931014050	4	VIS A METAUX - HM14x50 - 8,8
32	933014200	4	ÉCROU FREINE DIN 985 - M 14
33	937000010	1	RONDELLE DIN 127 - Ø10
34	934012125	1	ÉCROU ISO 4032 - M12
35	931510035	1	VIS A METAUX - HM10x35 - 8,8
36	931608055	1	VIS A METAUX - HM8x55 - 8,8
	933508125	5	ÉCROU FREINE DIN 985 - M 8
38	935520014	4	RONDELLE ISO 7089 - 14 - 140 HV
39	939408010	3	VIS DE PRESSION ISO 4026 - M8x16
40	922517012	2	PIGNON 17 DENTS 1/2
41	925053127	1	CHAÎNE 1/2" - 53 MAILLONS + MAILLON RAPIDE
42	925053127	1	CHAÎNE 1/2" - 53 MAILLONS + MAILLON RAPIDE
43	921506005	1	ROULEMENT 6005 - 2RS

44	923000035	1	PALIER PC/JT 35
45	931506016	48	VIS A METAUX - HM6x16 - 8,8
46	933506100	48	ÉCROUS FREINE ISO 10511 - M 6
47	9250P139S62	2	CHAÎNE S62 - 140 MAILLONS
48	933510150	10	ÉCROU FREINE DIN 985 - M10
50	926000062	2	MAILLON RAPIDE S62
52	9492C40405	1	CORNIÈRE PLASTIQUE
53	928500001	2	SECTIONS
54	935520005	4	RONDELLE M - D 5
55	932608020	4	VIS A METAUX - HM8x20 - 8,8
56	936030008	4	RONDELLE DIN6902 - A 8 - 200 HV
57	DN 15 01	1	COUVERCLE TAMBOUR
58	949526040	2	BOUCHON PLASTIQUE
60	919001025	2	POIGNÉE BAKÉLITE M10 x 25
61	931510070	5	VIS A METAUX - HM10x70 - 8,8
62	DN 62 00	5	RONDELLE D10-36
63	DN 63 00	1	ENTRETOISE 5MM
64	DN 64 00	1	ENTRETOISE 10MM
65	94200V1000	5	DENTS DE FENAISSON
66	921602520	24	BAGUE D'USURE Ø 25
67	915561000	28	GRAISSEURS
68	938055016	15	VIS AUTOPOREUSE Ø5 x 16
69	931510035	4	VIS A METAUX IFHC - M10x35 - 10,9
70	931505016	4	VIS A METAUX - HM5x16 - 8,8
71	933505080	4	ÉCROU FREINE DIN 985 - M5
72	9495603754	24	GUIDE PLASTIQUE POUR DOIGTS ESCAMOTABLES
73	9401BA8730	3	CLAVETTE 8 x 7 x 30 BOUT ARRONDI
74	922535012	1	PIGNON 35 DENTS 1/2"
75	DN 75 00	1	PIGNON 35 DENTS 1/2" PERCE
76	918600160	1	MOTEUR OMP 160
77	990000011	2	AUTOCOLLANT "ALTEC" BLANC
78	990000067	1	AUTOCOLLANT "LIRE LA NOTICE" HORIZONTAL
79	991000096	1	PLAQUE CONSTRUCTEUR
80	990000084	3	AUTOCOLLANT PASSAGE INTERDIT
81	990000075	1	AUTOCOLLANT "DT 120" BLANC

ALTEC

tél 33 565 29 95 88

fax 33 565 29 95 89

AXIAL STRAW SPREADING SYSTEM

Importör:

Närlant

Filarevägen 8, 703 75 Örebro

Tel: 019 - 603 60 60, Fax: 019 - 31 20 96

Webbadress: www.narlant.se

E-post: info@narlant.se

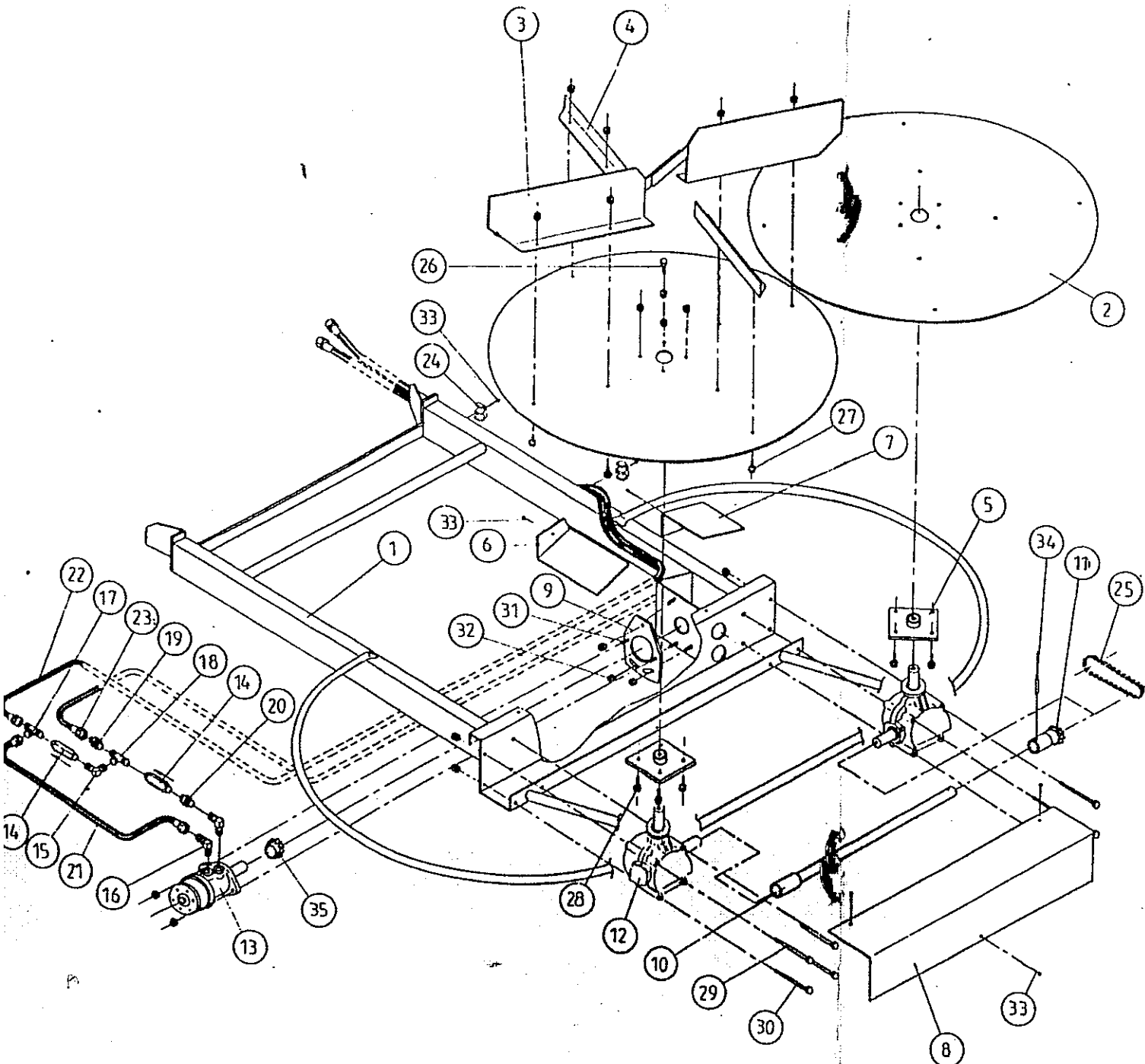

1. Frame	1
2. Discs (plates)	2
3. Big blade	4
4. Small blade	4
5. Disc bracket	2
6. Motor casing	1
7. Motor cover	1
8. Driving casing	1
9. Motor bracket	1
10. Driving shaft	1
11. Gear 17 teeth	1
12. Angle transmission	1
13. Hydraulic engine / motor	1
14. Non return valve	2
15. Knee union	2
16. Knee union CM13 G 3/8	2
17. T shaped union	1
18. T shaped union	1
19. Union AFE 13 G 3/8	1
20. Union UF 13 G 3/8	1
21. Hose - length 0,40 m	1
22. Hose - length 1,50 m	1
23. Hose - length 4,50 m	2
24. Clamp	2
25. Chain	1
26. Screw HM 8 L25	2
27. Screw HM 10 - L 20 + nut	16
28. Screw HM 10 - L 25 + nut	8
29. Screw HM 10 - L 110 + nut	4
30. Screw HM 10 - L 120 + nut	4
31. Screw F/90° HM10 L 40	2
32. Nut HM10	7
33. Self drilling screw	5
34. Pin bolt Ø 8 L 45	1
35. Gear 19 teeth	1